

Transient Voltage Suppressors (TVS) Data Sheet

Features

- Plastic package.
- Glass passivated chip junction in DO-41 Package
- Excellent clamping capability.
- Low zener impedance.
- 400W peak pulse power capability on 10/1000µs waveform.
- Typical IR less than 1µA above 13V.
- Fast response time: typically less than 1.0ps from 0 Volts to BV min.
- High temperature soldering guaranteed: 265°C/10 seconds
- AEC-Q101 qualified (Automotive grade with suffix "Q".)

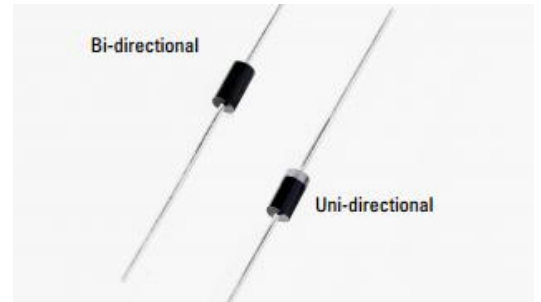

Mechanical Data

- Case: JEDEC DO-41 Molded Plastic.
- Terminals: Axial leads, solderable per MIL-STD-750, Method 2026.
- Polarity: Color band denoted cathode except bidirectional.
- Mounting Position: Any.

Maximum Ratings and Characteristics

Ratings at 25°C ambient temperature unless otherwise specified.

RATING	SYMBOL	VALUE	UNITS
Peak Pulse Power Dissipation on 10/1000us waveform (Note1, Fig.1).	P _{PPM}	Minimum 400	Watts
Peak Pulse Current of on 10/1000us waveform.(Note1, Fig.3)	I _{PPM}	See Table	Amps
Steady State Power Dissipation at TL =75°C, Lead lengths.375", (9.5mm) (Fig.5).	P _{M(AV)}	1.5	Watts
Peak Forward Surge Current, 8.3ms Single Half Sine-Wave Superimposed on Rated Load, (JEDEC Method) (Note 2, Fig.6).	I _{FSM}	40	Amps
Operating junction and Storage Temperature Range.	T _J , T _{STG}	-55 to +175	°C

Notes:

1. Non-repetitive current pulse, per Fig. 3 and derated above TA = 25°C per Fig. 2.
2. 8.3ms single half sine-wave, or equivalent square wave, Duty cycle = 4 pulses per minutes maximum.

Dimensions (DO-204AL/DO-41)

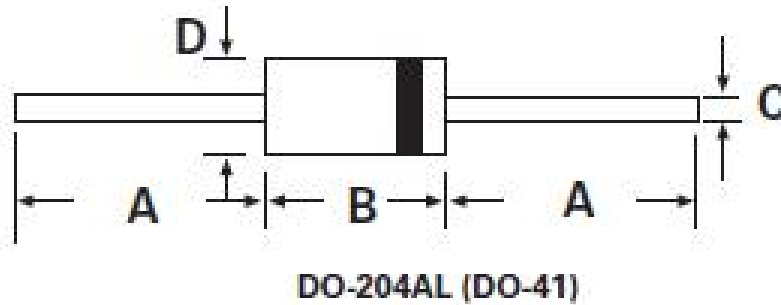

Item	Millimeters		Inches	
	Min.	Max.	Min.	Max.
A	25.40	-	1.000	-
B	4.10	5.20	0.160	0.205
C	0.71	0.86	0.028	0.034
D	2.00	2.70	0.080	0.107

Electrical Characteristics (T_A=25°C)

Part Number		Reverse Stand-Off Voltage	Breakdown Voltage NIN.@IT	Breakdown Voltage MAX.@IT	Reverse Leakage @VRWM	Test Current	Peak Pulse Current	Maximum Clamping Voltage @IPP
UNT	BI	VR(V)	VBL(V)	VBH(V)	IR(μA)	IT(mA)	IPP(A)	VCH(V)
P4KE6.8A	P4KE6.8CA	5.8	6.45	7.14	1000	10	39	10.5
P4KE7.5A	P4KE7.5CA	6.4	7.13	7.88	500	10	36.3	11.3
P4KE8.2A	P4KE8.2CA	7.02	7.79	8.61	200	10	33.9	12.1
P4KE9.1A	P4KE9.1CA	7.78	8.65	9.55	50	1	30.6	13.4
P4KE10A	P4KE10CA	8.55	9.5	10.5	10	1	28.3	14.5
P4KE11A	P4KE11CA	9.4	10.5	11.6	5	1	26.3	15.6
P4KE12A	P4KE12CA	10.2	11.4	12.6	5	1	24.6	16.7
P4KE13A	P4KE13CA	11.1	12.4	13.7	1	1	22.5	18.2
P4KE15A	P4KE15CA	12.8	14.3	15.8	1	1	19.3	21.2
P4KE16A	P4KE16CA	13.6	15.2	16.8	1	1	18.2	22.5
P4KE18A	P4KE18CA	15.3	17.1	18.9	1	1	16.1	25.5
P4KE20A	P4KE20CA	17.1	19	21	1	1	14.8	27.7
P4KE22A	P4KE22CA	18.8	20.9	23.1	1	1	13.4	30.6
P4KE24A	P4KE24CA	20.5	22.8	25.2	1	1	12.3	33.2
P4KE27A	P4KE27CA	23.1	25.7	28.4	1	1	10.9	37.5

Part Number		Reverse Stand-Off Voltage	Breakdown Voltage NIN.@IT	Breakdown Voltage MAX.@IT	Reverse Leakage @VRWM	Test Current	Peak Pulse Current	Maximum Clamping Voltage @IPP
UNT	BI	VR(V)	VBL(V)	VBH(V)	IR(uA)	IT(mA)	IPP(A)	VCH(V)
P4KE30A	P4KE30CA	25.6	28.5	31.5	1	1	9.9	41.4
P4KE33A	P4KE33CA	28.2	31.4	34.7	1	1	9	45.7
P4KE36A	P4KE36CA	30.8	34.2	37.8	1	1	8.2	49.9
P4KE39A	P4KE39CA	33.3	37.1	41	1	1	7.6	53.9
P4KE43A	P4KE43CA	36.8	40.9	45.2	1	1	6.9	59.3
P4KE47A	P4KE47CA	40.2	44.7	49.4	1	1	6.3	64.8
P4KE51A	P4KE51CA	43.6	48.5	53.6	1	1	5.8	70.1
P4KE56A	P4KE56CA	47.8	53.2	58.8	1	1	5.3	77
P4KE62A	P4KE62CA	53	58.9	65.1	1	1	4.8	85
P4KE68A	P4KE68CA	58.1	64.6	71.4	1	1	4.5	92
P4KE75A	P4KE75CA	64.1	71.3	78.8	1	1	4	103
P4KE82A	P4KE82CA	70.1	77.9	86.1	1	1	3.6	113
P4KE91A	P4KE91CA	77.8	86.5	95.5	1	1	3.3	125
P4KE100A	P4KE100CA	85.5	95	105	1	1	3	137
P4KE110A	P4KE110CA	94	105	116	1	1	2.7	152
P4KE120A	P4KE120CA	102	114	126	1	1	2.5	165
P4KE130A	P4KE130CA	111	124	137	1	1	2.3	179
P4KE150A	P4KE150CA	128	143	158	1	1	2	207
P4KE160A	P4KE160CA	136	152	168	1	1	1.9	219
P4KE170A	P4KE170CA	145	162	179	1	1	1.8	234
P4KE180A	P4KE180CA	154	171	189	1	1	1.7	246
P4KE200A	P4KE200CA	171	190	210	1	1	1.5	274
P4KE220A	P4KE220CA	185	209	231	1	1	1.3	328
P4KE250A	P4KE250CA	214	237	263	1	1	1.2	344

Notes: For bidirectional type having VRWM of 10 volts and less, the IR limit is double.

RATINGS AND CHARACTERISTIC CURVES ($T_A=25^\circ\text{C}$ unless otherwise noted)

Figure 1 - Peak Pulse Power Rating Curve

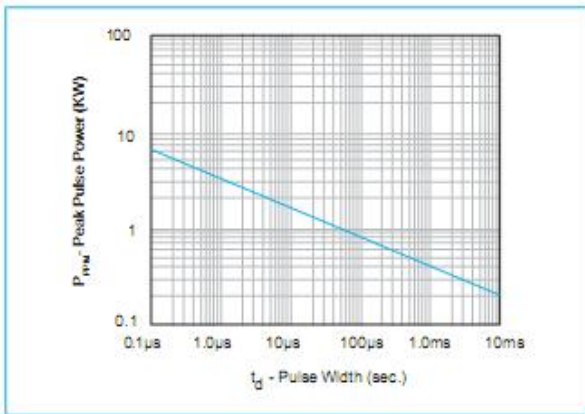

Figure 2 - Pulse Derating Curve

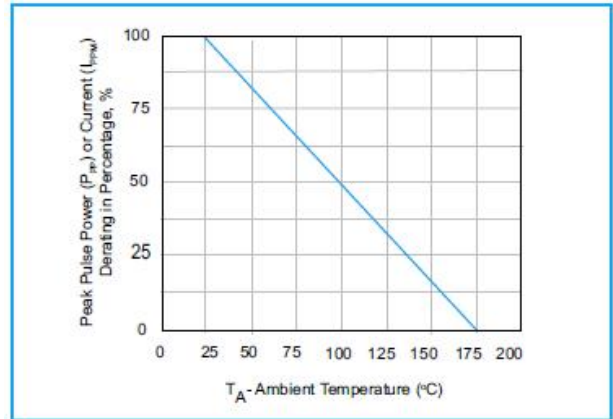

Figure 3 - Pulse Waveform

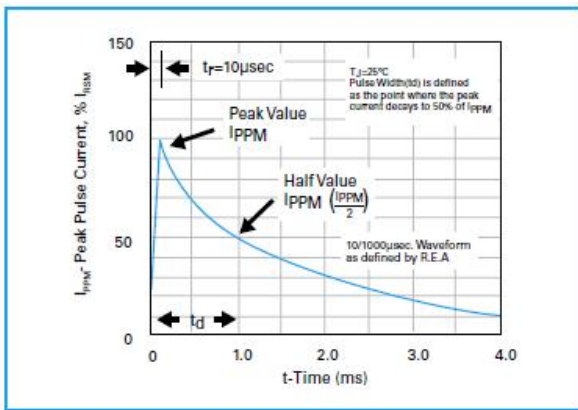

Figure 4 - Typical Junction Capacitance Uni-Directional

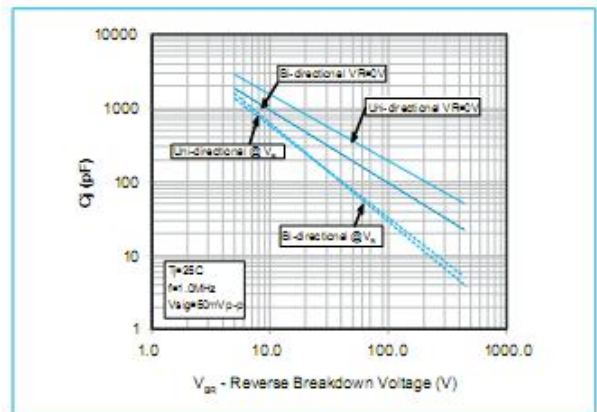

Figure 5 - Steady State Power Dissipation Derating Curve

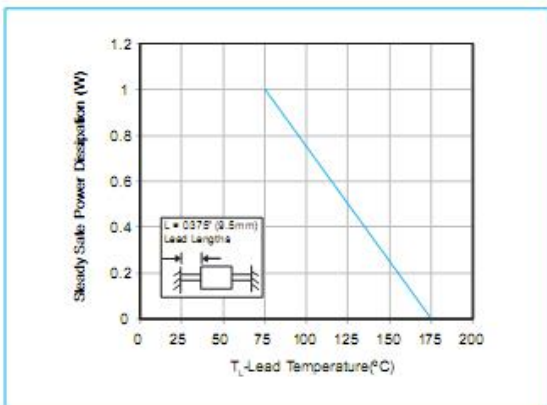

Figure 6 - Maximum Non-Repetitive Forward Surge Current Uni-Directional Only

